



Teflon Flexible Hose

Stainless Steel Braided



Hose Assemblies and End Connections

- Inner Tube Include Teflon PTFE and Teflon PFA
- Fitting Connection Sizes 1/4 to 1 in.
- Optional External Covers, Testing

HY-LOK CORPORATION

© 2019, 2020 HY-LOK CORPORATION All rights reserved

FOR A BETTER 

All Your Solution Provider "HY-LOK"



TOMORROW

Teflon Flexible Hose

INTRODUCTION

Hy-Lok Teflon flexible hose is an ideal solution for withstands continuous flexing, vibration and impulse for moving equipment high-purity fluids.

Variable length, high flexibility, high pressure and broad chemical compatibility are among the features that make this hose the preferred solution for many applications.

As a customer-focused company, Hy-Lok provides high-quality products and engineering solutions that address our customers' business and technical requirements.

GENERAL

Max. Pressure & Temperature

- Max allowable working pressure : 206 bar(3,000 psi) at 38°C (100°F)
- Max allowable temperature : 204 °C (400°F) max.

Materials

- Inner Tube : Teflon PTFE or Teflon PFA
- Braid : Stainless Steel 304 or 316
- External Cover(Optional) : Santoprene, Silicon
- End connection : Stainless Steel 316

Features / Benefits

- Teflon Inner Tube with stainless steel braid.
- External covering protect the braid from particles.(Option)
- Non contaminating material
- Maintains pure systems
- Teflon is FDA-approved material
- Hy-Lok Tube Fitting, Tube Adapter, Male & Female NPT connections.
- Packed and Validated for high purity service.

Teflon Inner Tube Stainless Steel Braided Hose

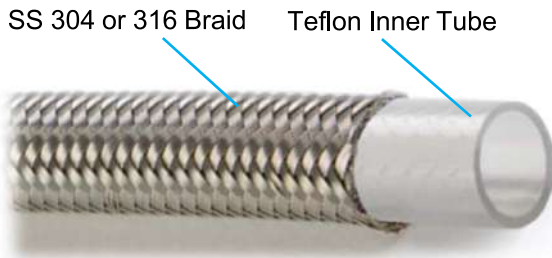

External Covered Teflon Inner Tube Stainless Steel Braided Hose

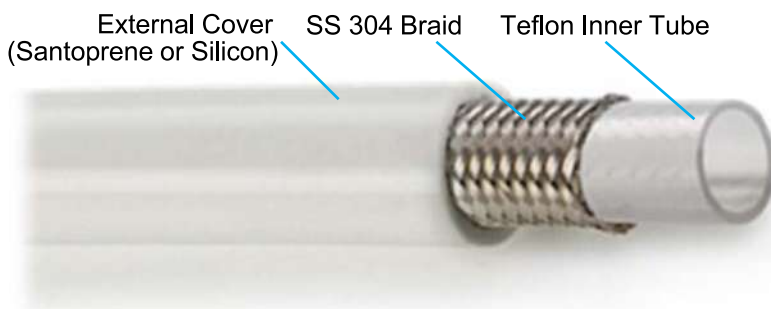

Teflon Flexible Hose

Hose Assemblies

Hy-Lok Tube Fitting End Connections



Fitting Size		Inside Diameter (mm)	Outside Diameter (mm)	Working Pressure (bar)	Burst Pressure (bar)	Min. Bending Radius	Hose Weight (Kg/m)
(in.)	(mm)						
1/4	6	4.7	8.0	206	827	50	0.13
5/16	8	6.4	9.1	206	827	76	0.19
3/8	10	7.9	10.7	172	689	100	0.20
1/2	12	9.5	12.7	137	551	127	0.22
3/4	20	16.0	20.0	83	332	195	0.31
1	25	22.2	26.2	69	275	225	0.48

Tube Adapter End Connections



Fitting Size		Inside Diameter (mm)	Outside Diameter (mm)	Working Pressure (bar)	Burst Pressure (bar)	Min. Bending Radius	Hose Weight (Kg/m)
(in.)	(mm)						
1/4	6	4.7	8.0	206	827	50	0.13
5/16	8	6.4	9.1	206	827	76	0.19
3/8	10	7.9	10.7	172	689	100	0.20
1/2	12	9.5	12.7	137	551	127	0.22
3/4	20	16.0	20.0	83	332	195	0.31
1	25	22.2	26.2	69	275	225	0.48

Male & Female NPT End Connections



Fitting Size		Inside Diameter (mm)	Outside Diameter (mm)	Working Pressure (bar)	Burst Pressure (bar)	Min. Bending Radius	Hose Weight (Kg/m)
(in.)	(mm)						
1/4	6	6.4	9.1	206	827	76	0.19
3/8	10	9.5	12.7	137	551	127	0.22
1/2	12	12.7	16.3	120	482	165	0.27
3/4	20	19.1	22.6	69	275	228	0.51
1	25	25.4	28.6	69	275	304	0.85

Travelling Loop Calculations

Constant Radius Traveling Loop A-Loop

FOR MAXIMUM VERTICAL TRAVEL

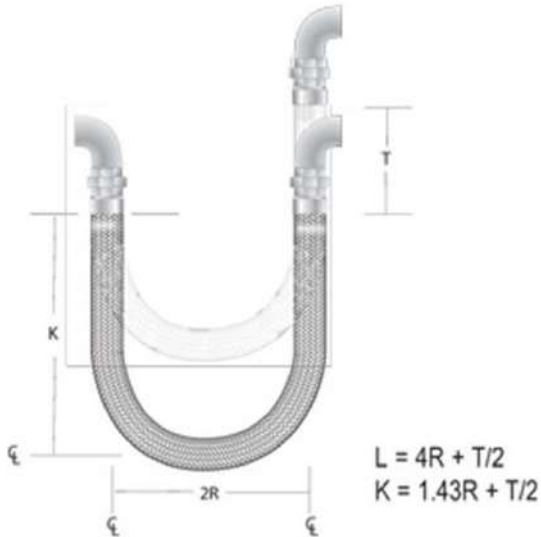

FOR MAXIMUM HORIZONTAL TRAVEL

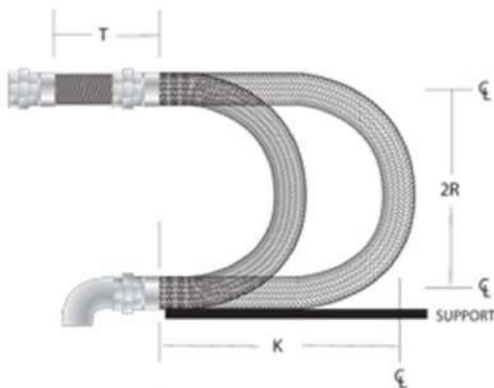

T = Total travel (in.)
 L = Hose live length (in.)
 R = Center line bend radius (in.)
 K = Loop Length (in.)

Variable Radius Traveling Loop B-Loop

FOR SHORT HORIZONTAL TRAVEL

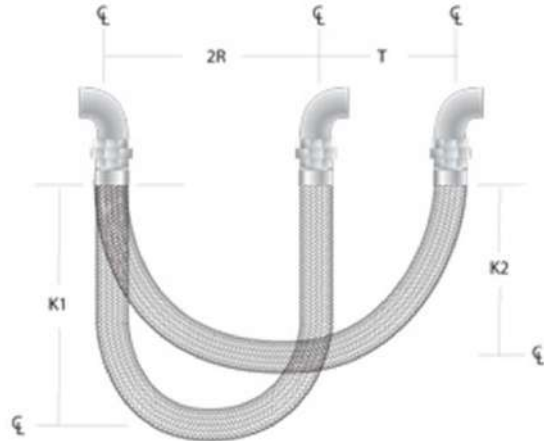

FOR SHORT VERTICAL TRAVEL

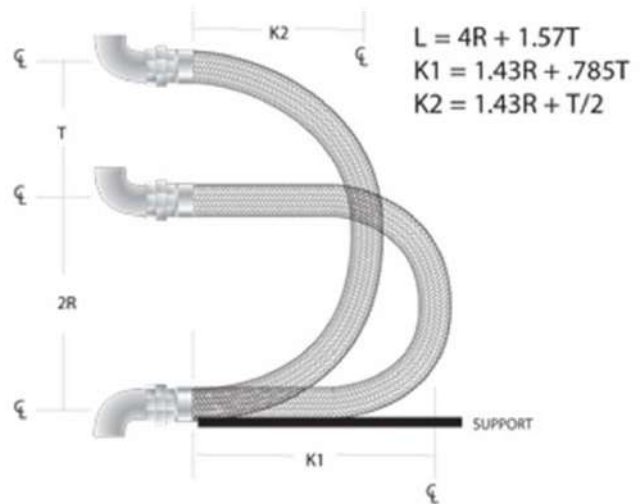

Note: In loop installations both connections and travel should be in same plane as the bend.